

Photoconductive terahertz antenna with radial symmetry

J.A. Deibel, M.D. Escarra and D.M. Mittleman

It has been demonstrated recently that it is possible to guide broadband terahertz pulses utilising a novel coaxial waveguide. This technique is hindered by the difficulty in exciting the radially polarised fundamental mode of the waveguide. To optimise mode matching, a novel radially symmetric photoconductive terahertz antenna is proposed. Using finite element method simulations and analytical calculations, it is shown that this antenna can generate the desired radial polarisation.

Introduction: Recently, considerable research effort has been committed to the development of waveguiding techniques that are compatible with the broadband terahertz pulses generated using terahertz time-domain spectroscopy (THz-TDS) [1, 2]. Because of the broad fractional bandwidth, such waveguides must exhibit not only low loss but also low group velocity dispersion. One promising class of waveguides that may be suitable are coaxial waveguides [3, 4]. These are frequently employed at lower frequencies [5] but rarely used in quasi-optical configurations, owing, in part, to the difficulties associated with input coupling. This coupling is challenging because the lowest-order (TEM) mode of such guides possesses a radial electric field polarisation [6]. This radial mode has a very poor spatial overlap with the linearly polarised wave conventionally generated by dipole antennas used in THz-TDS [7]. Here, we describe a novel cylindrically symmetric substrate antenna design which is compatible with THz-TDS. Using both analytical analysis and finite element methods, we explore the properties of the radiated far-field pattern, and show that it possesses the desired radial polarisation pattern.

Analytical calculations: Conventional THz-TDS systems use a dipole or similar patterned antenna, lithographically defined on a photoconducting substrate [4], to produce a wave with a uniform linear polarisation. In contrast, the antenna design of interest here (Fig. 1) possesses a cylindrical symmetry. As usual in THz-TDS, when a short optical pulse excites the region between the two DC-biased electrodes, an annular current surge is induced by the acceleration of the photogenerated carriers in the illuminated region.

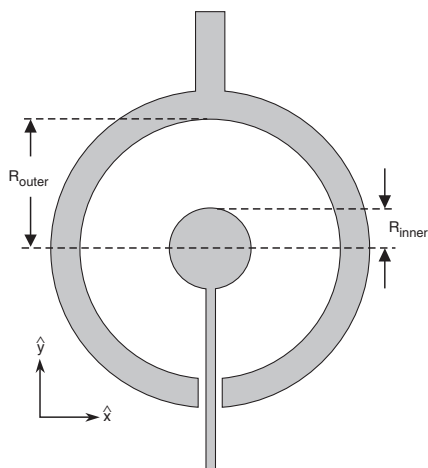

Fig. 1 Schematic of proposed radially symmetric antenna pattern

A simple calculation can be used to illustrate the principle of this substrate antenna. Neglecting the influence of the dielectric substrate, the radiated field can be thought of as a superposition of a large number of dipole fields, emitted by a series of point dipoles distributed on a circle, each pointing away radially from the origin. The resulting field can be computed easily, since the field from each one of these point dipoles can be found by simply shifting and rotating a classical far-field dipole pattern [8]. Then, the radiated power can be computed using superposition, as

$$P \simeq \frac{1}{2} \text{Re}[\vec{n} \cdot (\vec{E} \times \vec{H}^*)] = \frac{1}{2} \text{Re} \left[\vec{n} \cdot \left(\sum_i^N \vec{E}_i \times \sum_i^N \vec{H}_i^* \right) \right]$$

where \vec{E}_i and \vec{H}_i are the electric and magnetic fields for each dipole element. The effects of the feed lines are ignored. Fig. 2 shows the results of this computation (solid curve), demonstrating that no radiation is emitted in the plane of the antenna or along the axis of cylindrical symmetry perpendicular to the plane of the antenna. By rotating this result around this symmetry axis, it is clear that the emitted far-field mode is a ‘doughnut’ mode, as required for a radially polarised wave.

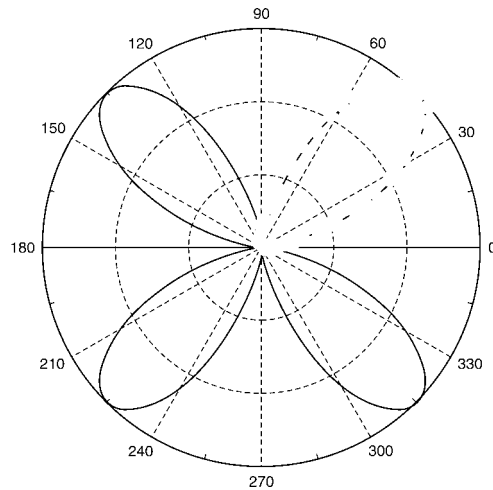

Fig. 2 Calculated far-field radiation pattern in y-z plane, neglecting substrate effects

Solid horizontal line indicates z-axis, which is the rotational symmetry axis of the antenna (if feed lines are ignored). Open circles show the results of FEM simulations in one quadrant, showing excellent agreement with computed pattern

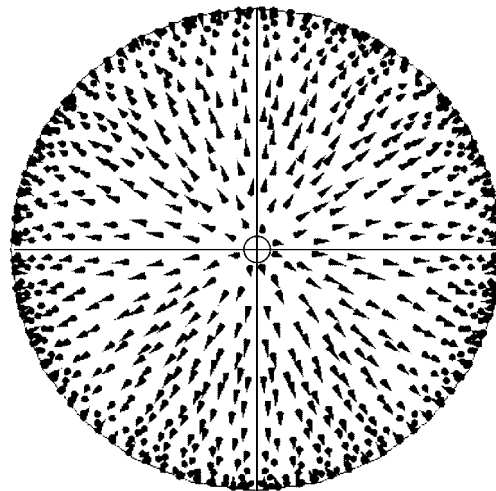

Fig. 3 Schematic plot of polarisation state of emitted beam in plane parallel to antenna plane (x-y plane), extracted from FEM simulation

Arrows depict local direction of electric field, showing expected radial polarisation pattern

Finite element method simulations: To account for the effects of the high dielectric substrate, we have also modelled this antenna design using a three-dimensional finite element method (FEM) package. A current distribution is defined in the y-z plane (the plane of the antenna) in a disc-shaped domain centred at the origin and bounded by an inner (R_{inner}) and outer (R_{outer}) radius. To approximate the annular current pattern of the antenna, the area encompassed by this disc is assigned the following time-varying current,

$$\vec{J} = \left[\left(\frac{y}{r} \alpha e^{-\beta r} \right) \hat{y} + \left(\frac{z}{r} \alpha e^{-\beta r} \right) \hat{z} \right] \epsilon_0 j \omega e^{j\omega t}$$

where α and β are constants chosen such that the magnitude of \vec{J} decays to zero at the outer edge of the disc. Low reflecting boundary conditions are used to eliminate finite size effects in the computation. Typically a mesh of approximately 60000 elements is used to compute the radiated

field pattern. We have modelled both the antenna in empty space, and also the more realistic situation of an antenna situated on a dielectric half space. For this latter case, we have used a dielectric of $\epsilon = 12.25$, the approximate value for GaAs. A stationary linear iterative solver was used to determine the electromagnetic fields emitted by the antenna at a variety of frequencies for both the free-space and half-space scenarios.

The results from the FEM simulations are in good agreement with the intuitive picture described above (see open circles in Fig. 2). Good agreement is observed in both the angle and width of the emitted lobe. Fig. 3 shows the polarisation of this annular field pattern, pointing away radially from the cylindrical symmetry axis. In the case of an antenna on a dielectric half-space, the lobed pattern is largely preserved, except that most of the energy is radiated into the substrate (see Fig. 4). This is similar to the effect observed for dipole substrate antennas [9].

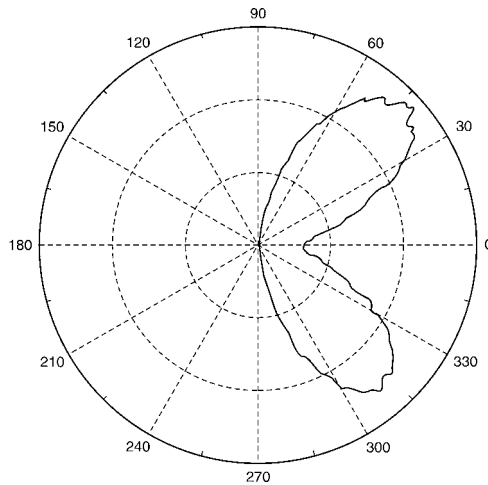

Fig. 4 Polar plot of radiation pattern for radial antenna on dielectric half-space, computed using FEM simulation

Here, 0° corresponds to z-axis. The vast majority (greater than 98%) of power is radiated into the high dielectric substrate, but the radial 'doughnut' mode is preserved

Conclusion: We have described a new design for a radially symmetric photoconductive terahertz antenna. Both analytical calculations and finite element method simulations predict that this design emits a radially polarised doughnut mode. This basic result is not affected by the presence of a high dielectric substrate. These findings should provide a valuable new method for mode matching to waveguides with coaxial symmetry.

© IEE 2005

11 November 2004

Electronics Letters online no: 20057824

doi: 10.1049/el:20057824

J.A. Deibel, M.D. Escarra and D.M. Mittleman (*Department of Electrical and Computer Engineering, Rice University, MS 366, PO Box 1892, Houston, TX 77251-1892, USA*)

E-mail: daniel@rice.edu

References

- Gallot, G., Jamison, S.P., McGowan, R., and Grischkowsky, D.: 'Terahertz waveguides', *J. Opt. Soc. Am. B*, 2000, **17**, pp. 851–863
- Mendis, R., and Grischkowsky, D.: 'Undistorted guided-wave propagation of subpicosecond terahertz pulses', *Opt. Lett.*, 2001, **26**, pp. 846–848
- Wang, K., Barkan, A., and Mittleman, D.M.: 'Propagation effects in apertureless near-field optical antennas', *Appl. Phys. Lett.*, 2004, **84**, pp. 305–307
- Wang, K., and Mittleman, D.M.: 'Metal wires for terahertz waveguiding', *Nature*, 2004, **432**
- Inan, U.S., and Inan, A.S.: 'Electromagnetic waves' (Prentice Hall, Upper Saddle River, NJ, 2000)
- Marcuvitz, N.: 'Waveguide handbook', Massachusetts Institute of Technology Radiation Laboratory Series (McGraw-Hill, New York, 1951)
- Rudd, J.V., Johnson, J.L., and Mittleman, D.M.: 'Cross-polarized angular emission patterns from lens-coupled terahertz antennas', *J. Opt. Soc. Am. B*, 2001, **18**, pp. 1524–1533
- Jackson, J.D.: 'Classical electrodynamics' (John Wiley & Sons, Inc., New York, 1999, 3rd edn.)
- Jepsen, P., and Keiding, S.R.: 'Radiation patterns from lens-coupled terahertz antennas', *Opt. Lett.*, 1995, **20**, (8), pp. 807–809