

Superprism effect in a metal-clad terahertz photonic crystal slab

Tushar Prasad and Vicki L. Colvin

Rice University, Department of Chemistry, MS-60, 6100 Main Street, Houston, Texas 77005, USA

Zhongping Jian and Daniel M. Mittleman

Rice University, Department of Electrical and Computer Engineering, MS-366, 6100 Main Street, Houston, Texas 77005, USA

Received October 9, 2006; revised November 15, 2006; accepted December 6, 2006;
posted December 15, 2006 (Doc. ID 75941); published February 15, 2007

We report an experimental demonstration of the superprism effect in a photonic crystal slab at terahertz frequencies. For a 10% frequency variation around 0.28 THz, the refraction angle at the output facet of a wedge-shaped photonic crystal varies by about 15°. A comparison with the predictions of a band structure calculation demonstrates that a three-dimensional treatment, accurately modeling the finite slab thickness and the metallic boundary conditions, is required for even a qualitative agreement with the experimental observations. © 2007 Optical Society of America
OCIS codes: 230.3990, 260.3090, 320.7100.

In recent years the field of photonic crystal research has been one of the most active areas of optics. It is now possible to predict, with extraordinary precision, the optical properties of very complex composite periodic structures.¹ However, in several important cases, even the most sophisticated theoretical treatments are inconsistent with experimental observations. A particularly relevant example is found in the superprism effect. Several recent studies have shown significant discrepancies between experimental results and the predictions obtained from numerical simulations² and also from band structure calculations based on the plane wave expansion method.³ The terahertz (THz) region of the spectrum is a useful window for studying such issues, because THz photonic crystals can be fabricated with essentially zero structural disorder.⁴ Indeed, it has recently been suggested that a purely two-dimensional theoretical treatment should be adequate for describing THz pulse propagation in a photonic crystal slab embedded in a parallel-plate metal waveguide.⁵ A careful study could therefore illuminate the origin of the discrepancies in earlier superprism measurements and provide impetus for further theoretical research.

In this Letter, we describe a study of the superprism effect at THz frequencies. Our sample is a photonic crystal slab, contained between a pair of parallel metal plates operating as a single-mode, broadband waveguide for TM-polarized radiation.⁴⁻⁶ The angle of refraction exhibits a strong frequency dependence, as anticipated for a superprism. We explore several options for simulating the experiment, including band structure calculations for both two- and three-dimensional photonic crystals⁷ and numerical modeling using both the finite-element method⁸ (FEM) and finite-difference time-domain² (FDTD) simulations. We find that a two-dimensional model is not useful for analyzing experiments in which the relevant portion of the photonic band structure lies above the light line. In the case of a

metal-clad slab, these leaky modes play an important role, particularly in the THz range.

For these measurements, we use a photonic crystal slab that has been cut into a triangular shape (Fig. 1). The sample is a 305 μm thick high-resistivity silicon wafer with a hexagonal array of circular 360 μm diameter holes etched all the way through.^{4,9} The lattice pitch is 400 μm . The input edge facet is perpendicular to the Γ - K direction of the hexagonal lattice, while the opposite edge is cut at an angle of 30° with respect to Γ - K , perpendicular to the Γ - M direction. This triangular slab is sandwiched between two polished copper plates, cut to the same triangular shape and size, which serve as a parallel-plate metal waveguide.¹⁰ This waveguide geometry offers low loss and low dispersion for single-mode propagation and has recently been used by several groups for waveguide-based THz spectroscopy.^{5,6,11,12}

Figure 1 shows the experimental setup for measuring angular dispersion. Broadband THz pulses are generated by a photoconductive antenna, collimated, and directed to the input facet of the photonic crystal slab. Silicon planocylindrical lenses are used to focus the THz beam into and out of the waveguide. The incident electric field is linearly polarized along the axis of the air cylinders to excite the lowest-order TM-polarized waveguide mode. Because of symmetry considerations associated with the mode matching of the incident wave to the TM modes of the parallel-plate waveguide, no higher-order guided modes are excited for frequencies below 0.5 THz.^{4,10,13} Thus, at all frequencies of interest in this Letter, the propagation is single mode and TEM. The THz radiation coupled into the waveguide undergoes frequency-dependent refraction at the output facet, after which it is detected by photoconductive sampling (Fig. 1). The $\sim 1.5^\circ$ angular resolution of these measurements is determined by the detector aperture. We have considered the possibility of small air gaps between the

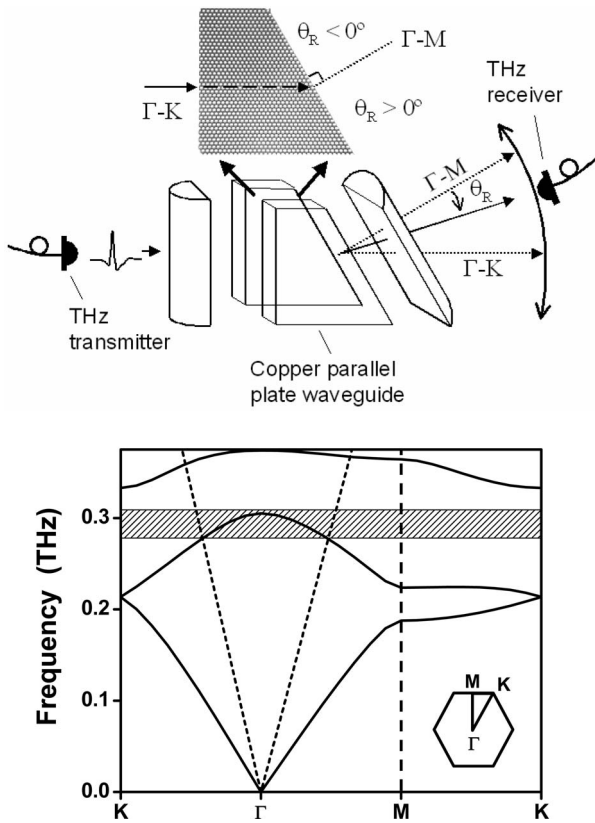

Fig. 1. Top, a schematic of the experimental arrangement. The input beam direction ($\Gamma-K$) and the output normal ($\Gamma-M$) are shown superimposed on a photograph of the photonic crystal slab. $\Gamma-M$ separates the region of positive and negative refraction. The triangular slab is contained between the plates of the metal waveguide. Bottom, band structure (TM polarization) of the photonic crystal slab, assuming infinite slab thickness, calculated by using the plane wave method. The superprism effect is observed in the frequency range depicted by the shaded region. The (dashed) light line is meaningful only for a three-dimensional photonic crystal, i.e., a photonic crystal slab with finite thickness. Inset, first Brillouin zone of the hexagonal lattice.

metal plates and the photonic crystal slab.¹² Such gaps would have a negligible effect on the measured refraction angle, unless they were unreasonably large.

Figure 2 shows a summary of the observed spectra in the narrow frequency range of interest. An abrupt shift in the frequency of the diffracted field is observed as the angle is varied over a small range, characteristic of the superprism phenomenon.¹⁴ Figure 3 summarizes these experimental results (filled circles), showing a $\sim 15^\circ$ shift for only a 10% change in frequency.

The physical explanation of the superprism effect is usually derived from photonic band structure calculations.¹⁴ In our measurements, the superprism effect is observed in the vicinity of the edge of the second band (shaded portion of the band structure in Fig. 1, which was computed assuming an infinite slab thickness). It is immediately clear that this effectively two-dimensional treatment cannot provide even a qualitative explanation of the observed results. In the relevant region of the band structure,

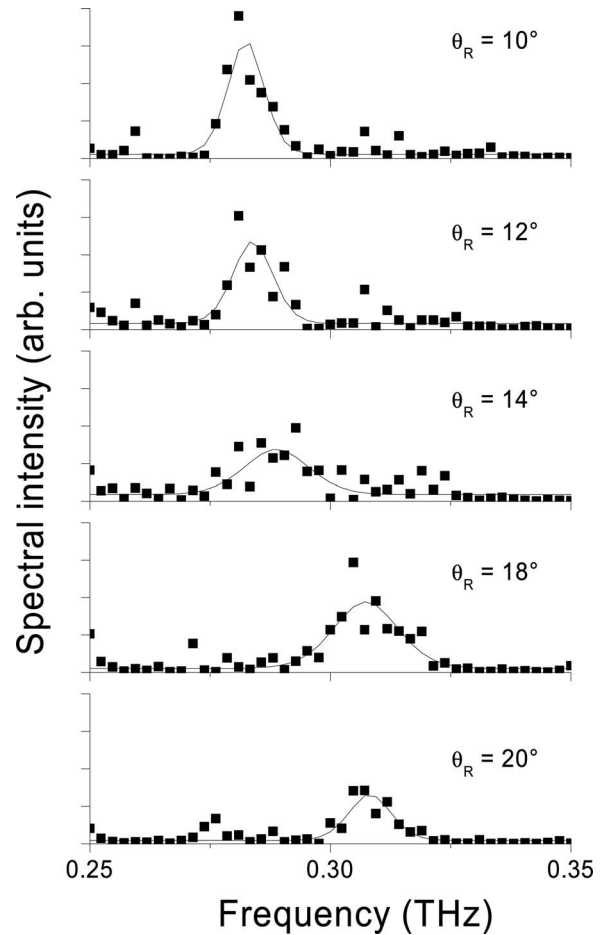

Fig. 2. Portion of the intensity spectrum of the diffracted THz radiation at several different angles, showing the spectral range of interest. The angle θ_R is defined in Fig. 1. The solid curves are Gaussian best fits to the data, and are shown as guides to the eye.

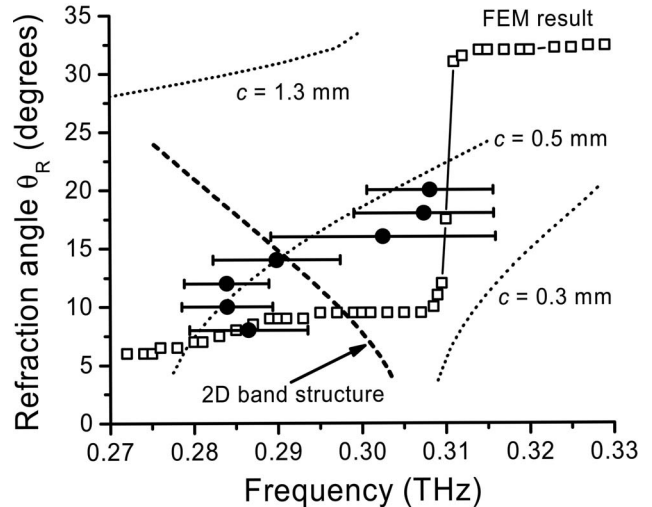

Fig. 3. Measured angular dispersion for the TM modes (filled circles with error bars). The dashed curve shows the prediction obtained using a two-dimensional band structure calculation (see Fig. 1), while the dotted curves show the results for an air-clad two-dimensional slab with different values of the periodicity parameter c , as described in the text. The open squares depict the predicted angular dispersion obtained using a FEM simulation.

the band curvature is negative, which implies negative angular dispersion (i.e., decreasing refraction angle with increasing frequency; see the dashed curve in Fig. 3). The experimental data, however, clearly exhibit *positive* angular dispersion. Evidently, the band curvature in this portion of the band structure is not accurately predicted by a two-dimensional model.⁵

This result illustrates the importance of including finite thickness effects in modeling metal-clad photonic crystal slabs. We note that the portion of the band structure sampled by our measurements, which lies *above* the light line, is often neglected because it describes the leaky modes of the slab. However, because of the metallic boundary conditions, even leaky modes can remain confined in the plane of the slab and propagate through the photonic crystal. This is particularly true in the THz regime, where ohmic losses due to the metal are much smaller than in the visible and near infrared. Thus, to accurately simulate these experiments, the finite thickness of the slab and its boundary conditions cannot be ignored.

The requirement to include finite thickness effects makes the modeling of such experiments far more challenging. The plane wave method used to calculate the two-dimensional band structure (Fig. 1) can also be used to obtain the band structure of the photonic crystal with finite thickness by imposing an artificial periodicity in the third dimension, with a repeat period c that is chosen arbitrarily.⁷ This approach assumes air spacing in the region between repeated slabs. The dotted curves in Fig. 3 show the results obtained by using several different values for the period c , corresponding to the thickness of the hypothetical air cladding. These results show that the modes above the light line are strongly affected by the choice of c , such that essentially any (positive) value of angular dispersion can be obtained. As a result, although it is possible to obtain reasonable agreement with the experimental results with one particular choice of c , the predictive value of this approach is limited.¹⁵

Numerical methods such as FDTD and FEM are also widely used to predict the performance of photonic crystal devices.^{16,17} It has proved to be challenging to obtain good agreement with experimental results in certain cases, particularly with superprism effects. For example, Malkova *et al.* noted that FDTD calculations can strongly disagree with band structure predictions, especially for frequencies near a band edge where the group velocity is small.² The discretization limits of FEM simulations have also been discussed.⁸

We perform three-dimensional FEM calculations to simulate the wedge-shaped slab sandwiched between metal plates. The whole structure is discretized such that the biggest mesh feature is $15\ \mu\text{m}$ in the area containing the photonic crystal, which results in a model with roughly 2.9 million mesh elements. A plane wave is launched in the Γ - K direction toward

the input facet, and the output angle at the slanted facet of the crystal is extracted for each frequency. The result is shown as open squares in Fig. 3. As in the case of earlier superprism studies,^{2,3} the agreement with the experimental measurements is only qualitative, although at least the sign of the angular dispersion is correct. We have also performed FDTD simulations (not shown) and encountered similar difficulties as in Ref. 2. These results highlight the need for more sophisticated methods for simulation of complex structures containing metallic boundaries.

In conclusion, we have demonstrated the superprism effect in a photonic crystal slab at THz frequencies. The experimental results are in clear disagreement with a two-dimensional band structure calculation, indicating that a three-dimensional approach incorporating the finite thickness and boundary conditions is required. We expect that these results will inspire further theoretical work directed toward the accurate computation of photonic crystal modes lying above the light line.

This work has been supported in part by the National Science Foundation, the R. A. Welch Foundation, the American Chemical Society Petroleum Research Fund, and the Office of Naval Research. D. Mittleman's email address is daniel@rice.edu.

References

1. J. D. Joannopoulos, R. D. Meade, and J. N. Winn, *Photonic Crystals: Molding the Flow of Light* (Princeton U. Press, 1995).
2. N. Malkova, D. A. Scrymgeour, and V. Gopalan, *Phys. Rev. B* **72**, 45144 (2005).
3. L. J. Wu, M. Mazilu, T. Karle, and T. F. Krauss, *IEEE J. Quantum Electron.* **38**, 915 (2002).
4. Z. P. Jian, J. Pearce, and D. M. Mittleman, *Semicond. Sci. Technol.* **20**, S300 (2005).
5. Y. Zhao and D. Grischkowsky, *Opt. Lett.* **31**, 1534 (2006).
6. Z. P. Jian, J. Pearce, and D. M. Mittleman, *Opt. Lett.* **29**, 2067 (2004).
7. S. G. Johnson, S. H. Fan, P. R. Villeneuve, J. D. Joannopoulos, and L. A. Kolodziejski, *Phys. Rev. B* **60**, 5751 (1999).
8. L. Pierantoni, A. Massaro, and T. Rozzi, *IEEE Photon. Technol. Lett.* **18**, 319 (2006).
9. N. Jukam and M. S. Sherwin, *Appl. Phys. Lett.* **83**, 21 (2003).
10. R. Mendis and D. Grischkowsky, *Opt. Lett.* **26**, 846 (2001).
11. J. Zhang and D. Grischkowsky, *Opt. Lett.* **29**, 1617 (2004).
12. R. Mendis, *Opt. Lett.* **17**, 2643 (2006).
13. G. Gallot, S. Jamison, R. McGowan, and D. Grischkowsky, *J. Opt. Soc. Am. B* **17**, 851 (2000).
14. H. Kosaka, T. Kawashima, A. Tomita, M. Notomi, T. Tamamura, T. Sato, and S. Kawakami, *Phys. Rev. B* **58**, 10096 (1998).
15. M. Kafesaki, M. Agio, and C. M. Soukoulis, *J. Opt. Soc. Am. B* **19**, 2232 (2002).
16. T. Baba, T. Matsumoto, and M. Echizen, *Opt. Express* **12**, 4608 (2004).
17. A. L. Pokrovsky, *Phys. Rev. B* **69** (2004).